

## 阅读申明

- 1.本站收集的数据手册和产品资料都来自互联网，版权归原作者所有。如读者和版权方有任何异议请及时告之，我们将妥善解决。
- 2.本站提供的中文数据手册是英文数据手册的中文翻译，其目的是协助用户阅读，该译文无法自动跟随原稿更新，同时也可能存在翻译上的不当。建议读者以英文原稿为参考以便获得更精准的信息。
- 3.本站提供的产品资料，来自厂商的技术支持或者使用者的心得体会等，其内容可能存在描述上的差异，建议读者做出适当判断。
- 4.如需与我们联系，请发邮件到marketing@iczoom.com，主题请标有“数据手册”字样。

## Read Statement

1. The datasheets and other product information on the site are all from network reference or other public materials, and the copyright belongs to the original author and original published source. If readers and copyright owners have any objections, please contact us and we will deal with it in a timely manner.
2. The Chinese datasheets provided on the website is a Chinese translation of the English datasheets. Its purpose is for reader's learning exchange only and do not involve commercial purposes. The translation cannot be automatically updated with the original manuscript, and there may also be improper translations. Readers are advised to use the English manuscript as a reference for more accurate information.
3. All product information provided on the website refer to solutions from manufacturers' technical support or users the contents may have differences in description, and readers are advised to take the original article as the standard.
4. If you have any questions, please contact us at marketing@iczoom.com and mark the subject with "Datasheets" .

# 1.2M 跌落测试报告

## 1.2M Drop Test Report

<b>Client</b> 委托方	SHENZHEN PKCELL BATTERY CO., LTD. 深圳市比苛电池有限公司
<b>Add. of Client</b> 委托方地址	2nd Floor, 4th Building, Meitai Technology Park, No.1231, Guanguang Road, Osmanthus Community, Guanlan Town, Longhua New Area, Shenzhen 深圳市龙华新区观澜街道桂花社区观光路 1231 号美泰科技园肆号厂房贰楼
<b>Samples Description</b> 样品名称	Rechargeable Lithium-Ion Polymer Battery 可充电锂离子聚合物电池
<b>Model/Type</b> 型号规格	LP103450
<b>Testing Laboratory</b> 测试机构	Shenzhen NCT Testing Technology Co., Ltd. 深圳诺测检测技术有限公司 1 / F, No. B Building, Mianshang Younger Pioneer Park, Hangcheng Road, Gushu Xixiang Street, Baoan District, Shenzhen, Guangdong, China 中国广东省深圳市宝安区西乡街道固成航城大道绵商青年创业园 B 栋第 1 层
<b>Report No.</b> 报告编号	NCT17010119B1-2
<b>Issued Date</b> 发行日期	Mar. 10, 2017
<b>Test Conclusion 测试结论:</b> Shown in the Conclusion of test report. 见检测报告结论页.	

Tested by 主检人: Klaus Peng

Approved by 批准人: \_\_\_\_\_

Inspected by 审核人: Hely Wang

Seal of NCT 报告单位 (盖章)

Date of Issue 签发日期: 2017. 03. 10



**I、SAMPLE DESCRIPTION 样品描述**

<b>Product Name</b> 产品名称	Rechargeable Lithium-Ion Polymer Battery 可充电锂离子聚合物电池		<b>Sample Model</b> 样品型号	LP103450	
<b>Manufacturer</b> 制造商	SHENZHEN PKCELL BATTERY CO., LTD. 深圳市比苛电池有限公司				
<b>Address</b> 地址	2nd Floor, 4th Building, Meitai Technology Park, No.1231, Guanguang Road, Osmanthus Community, Guanlan Town, Longhua New Area, Shenzhen 深圳市龙华新区观澜街道桂花社区观光路 1231 号美泰科技园肆号厂房贰楼				
<b>Trade Mark</b> 商标	PKCELL	<b>Cell Shape</b> 电芯形状	Prismatic 棱柱形	<b>Packaging dimensions</b> 包装尺寸 (L×W×T)	(430×300×300)mm
<b>Nominal Voltage</b> 标称电压	3.7V	<b>Rated Capacity</b> 额定容量	2000mAh 7.4Wh	<b>Battery Number</b> 电池数量	60/PCS
<b>Gross weight per package</b> 每包装件毛重	12.3kg		<b>Net weight of batteries per package</b> 每包装件锂离子电池的净重	1.68kg/packing	
<b>Receiving Date</b> 接收日期	Mar. 07, 2017		<b>Completing Date</b> 完成日期	Mar. 10, 2017	

**II、STANDARD 标准**

Section II of Packing Instructions 966 of 58<sup>th</sup> DGR Manual of IATA.

IATA《危险品规则》(58版)包装说明 966 第 II 章节。

Special provision 188 of INTERNATIONAL MARITIME DANGEROUS GOODS CODE (Amdt.38-16)

IMO《国际海运危险货物规则》(38-16版)特殊规定 188 条款。

**III、TEST ITEM 测试项目**

- 1). Drop test 跌落测试
- 2). Packing weight test 包装重量测试

**IV、TEST METHOD 测试方法**

The package of batteries is dropped from 1.2m, 5times per package. The test floor is concrete floor, each package is capable of withstanding a 1.2 meter drop test in any orientation without damage to cell or batteries contained therein. Without shifting of the contents so as to allow battery to battery (or cell to cell) contact and without release of contents.

电池包装件(或含有电池的包装件)从 1.2 米高度进行跌落,每个包装件 5 次.测试底板为混凝土底板,每一个包装件应能承受在任一方位的 1.2 米跌落测试,并且没有电芯或电池损坏.没有位移导致电池或电芯相互接触,并没有内部物品从箱体漏出.

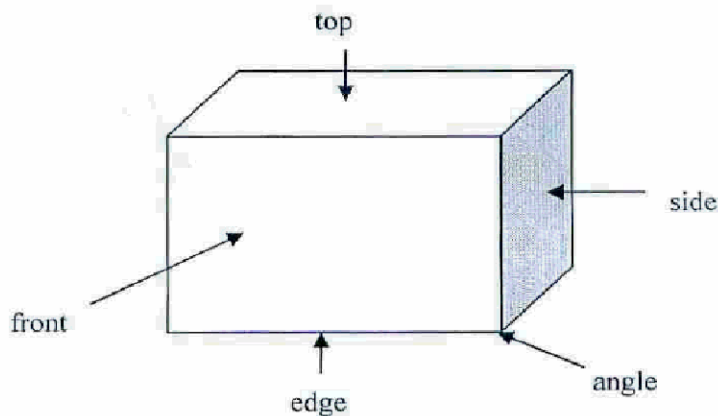

### V、TEST APPARATUS 测试仪器

Serial No. 设备编号	Name of Equipment 设备名称	Model 型号	Calibration Date /Due Date 校准日期/到期日
NCT-013	Single-blade drop tester 单翼跌落测试仪器	GX-6050-A	2017. 03. 04
			2018. 03. 03
NCT-008	Electronic scale 电子秤	JSC-S30	2017. 03. 04
			2018. 03. 03

### VI、TEST RESULT 测试结果

#### 1) Drop test 跌落测试

Drop position 跌落位置	Test status 测试情况	Conclusion 结论
Front 前面	Without damage packaging 包装没有损坏	Pass 合格
Bottom 底部	Without damage packaging 包装没有损坏	Pass 合格
Angle 角	Without damage packaging 包装没有损坏	Pass 合格
Side 侧面	Without damage packaging 包装没有损坏	Pass 合格

Top 顶部	Without damage packaging 包装没有损坏	Pass 合格
-----------	------------------------------------	------------

### 2) Packing weight test 包装重量测试

No. 编号	Test item 测试项目	Weight 重量 (kg)	Remark 备注
1	Packing weight test 包装重量测试	12.3	---

### Photos 照片

#### Samples 样品:

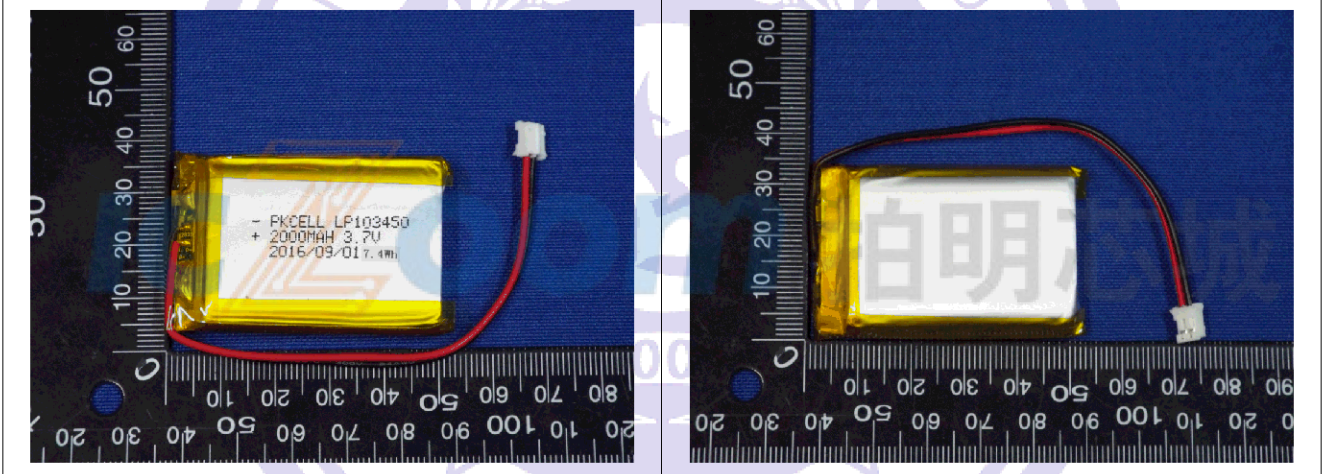

#### Equipment 设备:

